

COUNTY COUNCIL of BERKELEY
COUNTY, WEST VIRGINIA

Request for Proposal (RFP)
For
Eastern Panhandle Transit Authority
Transfer Station
Site & Building Preparation Work
South Raleigh Street & West South Street

Bid Proposal due no later than
4:00 PM, Wednesday, August
14, 2019 in the County Council
Office, Room 201, 400 W.
Stephen Street, Martinsburg,
WV, 25401

July 2019

**REQUEST FOR PROPOSALS
REGARDING QUALIFICATION AND PRICE PROPOSALS FOR
EASTERN PANHANDLE TRANSIT AUTHORITY SITE & BUILDING PREPARATION
WORK**

The County Council of Berkeley County, West Virginia (herein referred to as the "County Council" or "Council") is requesting Qualification and Price Proposals from interested parties for the site and building preparation work needed for an Eastern Panhandle Transit Authority (EPTA) Transfer Station to be erected at the corner of South Raleigh Street and West South Street in Martinsburg, WV, 25401.

The County Council (or its designated representatives) will be evaluating submissions to this request and will ultimately select a firm judged to be both responsible and responsive to the request in every way, including having offered the most beneficial, appropriate price proposals. The County Council reserves the right to interview some or all prospective firms to discuss Qualifications & Price Proposals. The format for submittals, information regarding the scope of work, and selection criteria used by the County Council is available from the County Council Office, 400 W. Stephen Street, Suite 201, Martinsburg, WV 25401, or by telephone at 304-264-1923. Inquiries should be directed to Jack Laing, Facilities Director, at 304-267-3000.

Three (3) copies of submittals of Qualification & Price information from interested businesses should be enclosed in a sealed opaque envelope marked "**EPTA Site & Building Preparation Work**". Proposals must be submitted and time-stamped into the County Council Office, Room 201, 400 W. Stephen Street, Martinsburg, WV, 25401 **no later than 4:00 PM on Wednesday, August 14, 2019**. Failure to provide the required information as requested in the RFP for Berkeley County's review may result in disqualification.

Proposals will be opened and entered into public record at 10:10 AM on Thursday, August 15, 2019 in the County Council Meeting Room, 400 W. Stephen Street, Room 205, Martinsburg, WV, 25401.

Berkeley County shall make positive efforts to utilize Disadvantaged Business Enterprises for its supplies and services and shall allow these sources the maximum feasible opportunity to compete for contracts. Berkeley County does not discriminate on the basis of race, color, national origin, sex, religion, age or disability for the provision of services.

Berkeley County reserves the right to accept or reject any or all proposals, to waive technicalities, and to take whatever action is in the best interest of the Berkeley County Council.

I. INTRODUCTION:

Proposals are being requested from Contractors to submit bids for site and building preparation work needed for the erection of an Eastern Panhandle Transit Authority (hereinafter referred to as "EPTA") Transfer Station to be located at the corner of S. Raleigh Street and West South Street in Martinsburg, West Virginia as ordered by the County Council of Berkeley County, West Virginia, (hereinafter referred to as "County Council" or "Council"). Only written responses to this RFP shall be considered. All materials submitted shall become part of the proposal.

II. BACKGROUND:

Berkeley County is located in the eastern panhandle of West Virginia. According to 2010 Census information, Berkeley County has a population of 104,169 making it the second-most populous county in West Virginia, behind Kanawha. Martinsburg is the County Seat.

The county lies adjacent to the Washington-Baltimore Metropolitan area and is one of three counties in the Hagerstown-Martinsburg, MD-WV Metropolitan Statistical Area.

Partly because of its proximity to Washington, D.C., Berkeley County is the fastest growing county in the State of West Virginia and among the fastest growing in the entire country.

Berkeley County is currently governed by a five (5) member County Council.

III. SCOPE OF WORK

A. GENERAL

The County Council is requesting bids from Contractors for site work and building preparation work needed for the erection of an EPTA Transfer Station located at the corner of South Raleigh Street and West South Street in Martinsburg, WV, 25401

1. GUIDELINES AND REQUIREMENTS

- a. The proposed scope of work will be coordinated with the County through Mr. Jack Laing, Facilities Director, and will include services pre-construction, during construction, and post-construction.
- b. In accordance with plans provided under Attachment "C" and Attachment "D", the successful contractor will be responsible for:
 - Site work.
 - Building preparation work.
 - Demolition and replacement of approximately 105 linear feet of curbing, as required.
 - Demolition and replacement of approximately 6,714 square feet of blacktop, as required.
 - Upon removal of blacktop, removal of all spoil from site and replacement of shale necessary to bring site to grade.
 - Remove approximately 245 cubic yards of old soil and backfill. All shale used as backfill must be compacted per code.
 - Assuring that all subgrade be plus or minus one-tenth (1/10) on grade assuring that the pad has the necessary hardware in place for the erection of the transfer station structure and accompanying benches.

- c. Successful bidder will be expected to commence work immediately upon bid award.
- d. Contractor will assure that all grading complies with all federal, state and local requirements.
- e. Contractor must contact Jack Laing at 304-267-3000 should there be any questions or problems.
- f. Project is not subject to prevailing wage rate.
- g. Berkeley County is a tax exempt organization. Tax number 55-6000296.

IV. Q&E /TECHNICAL PROPOSAL:

Respondent shall respond to and reference each section and subsection for portion(s) of RFP proposal. *At a minimum, your Qualifications Proposal shall include the following information. Failure to discuss each item may deem the submittal non-responsive and may result in non-- consideration of respondent's services.*

A. Firm Information

- 1. Name, address, telephone number, fax number of Contracting firm and parent company, if any, from which the project will be managed.
- 2. Nature of Contracting firm and parent company, if any.

B. Firm Capabilities

- 1. Describe the size of your firm/project office as related to size of staff.

C. Firm Principals and Background

- 1. Submit the names, titles, and resumes of the "principal" staff member(s) who will be responsible for the project during the performance of the contract. Please assure that the information provided includes specialized experience and technical competence in providing relevant services on similar sized projects during the past three (3) years.
- 2. Describe in depth the operations team available to the "principal" staff member(s). Include an organizational chart of manpower, titles, qualifications, roles in contract performance, and availability for telephone consultations and on-site meetings.
- 3. Provide a list of at least three (3) but no more than five (5) similar and/or relevant projects that you have completed during the past five (5) years. This information must include the business name, contact person, address, email address, and phone number.

D. All technical proposals should include any conclusions, remarks and/or supplemental

information that is pertinent to this request. Submitters are also required to provide written information regarding their inability to conform to any of the technical requirements listed above. Failure to do so will result in disqualification of proposal.

V. PRICE PROPOSAL:

- A. At a minimum, your Price Proposal shall include the following:
1. A lump-sum price quotation for all services listed-Attachment A
 2. Fully executed Non-Collusion Certificate - Attachment B.
 3. Proof of current business licenses.
 4. Any conclusions, remarks and/or supplemental information pertinent to this request.

VI. TERM OF CONTRACT:

- A. The contract will commence upon award by the County Council.
- B. If the Firm and/or Company awarded the bid subsequently fails to comply with the specifications, it will be given thirty (30) calendar days' notice to render satisfactory service. If at the expiration of such thirty (30) calendar days' notice, the unsatisfactory conditions have not been corrected, the County Council reserves the right to terminate the contract.

VII. USE OF EXISTING DOCUMENTS:

Berkeley County will cooperate to the fullest extent by making available to the Firm/Company all documents pertinent to this service that may be in the County Council's possession. Berkeley County makes no warranty as to the accuracy of existing documents nor will the County Council accept any responsibility for errors and omissions that may arise from the Firm/Consultant having relied upon them.

VIII. COMPENSATION TO THE CONTRACTOR:

Invoices must be submitted on an AIA form based on a draw down schedule agreed upon prior to commencement of work. Invoices are to be submitted to:

Berkeley County Council
400 W. Stephen Street
Suite 201
Martinsburg, WV, 25401

Payment will be made within thirty (30) days of receipt and approval.

IX. INSURANCE REQUIREMENTS:

Professional Liability – The successful Bidder must show evidence of professional liability insurance coverage in the amount of one million (\$1,000,000) dollars, with a minimum coverage of one million (\$1,000,000) dollars per occurrence and one million (\$1,000,000) dollars aggregate and must include coverage for errors, omissions and negligent acts, prior to execution of a contract with Berkeley County.

X. PERFORMANCE, PAYMENT AND MAINTENANCE BONDS:

The successful Bidder will be required to furnish, at the Bidder's expense, a Performance Bond and a Labor and Material Payment Bond for One Hundred Percent (100%) of the contract award. Bonds must be issued by a company licensed to transact surety insurance in West Virginia.

XI. SELECTION PROCESS:

- A. This solicitation is issued pursuant to the implementation of Berkeley County's Purchasing Policy. Berkeley County shall not be liable for any costs not included in the proposal, not contracted for subsequently, or in regard to preparation of your proposal.
- B. A Selection Committee appointed by the County Council will evaluate responses to this request and select those firms judged to be most qualified.
- C. It is the County Council's intent to open and review each firm's Qualifications & Experience/ Technical Proposal to determine a firm's qualifications, experience and technical approach to the services. If the Selection Committee determines that a firm's Qualifications & Experience/Technical Proposal is acceptable, than price will be considered.
- D. Since it is the County Council's desire to select the most qualified firm, the Selection Committee reserves the right to schedule oral presentations from those firms it deems most qualified, to take place within ten (10) business days following notification.
- E. Selection criteria to be used by the Committee are:
 - 1. Responsiveness to the scope of work and these instructions;
 - 2. Past performance of the firm including timely completion of services, compliance with scope of work performed within budgetary constraints, and user satisfaction;
 - 3. Specialized experience and technical competence in performing relevant services in the past ten (10) years, including qualifications of staff members who will be involved in these services;
 - 4. Oral presentations, if required;
 - 5. Composition of the principals and staff assigned to provide these services, particularly the proposed manager and immediate staff, and their qualifications and experience with services such as that being proposed;

6. Adequacy of the personnel of the firm to accomplish the proposed scope of work in the required time;
7. Firm's capacity to perform the work, giving consideration to current workloads;
8. Firm's familiarity with problems applicable to this type of services;
9. References from previous clients, including size and scope of the services, name and telephone number of contact person.
10. Price Proposal.

XII. PROPOSALS AND AWARD SCHEDULE:

- A. Proposals received prior to the deadline will be treated as confidential, until receipt of all Proposals and opening of the same. Proposals received after the deadline will not be considered in the evaluation process and will be returned unopened.
- B. It is expected that the contract award will be made within forty-five (45) calendar days after the opening of proposals. The contract will be awarded to the Company whose proposal, conforming to this request, will be the most advantageous to Berkeley County.
- C. Proposals must give the full name and address of the proposer and the person signing the proposal shall indicate his or her title and/or authority to bind the firm in a contract.
- D. Proposals may not be altered or amended after they are opened.
- E. The approval or disapproval of the Company's Proposal will be determined by its response to this request and on past performance. No assumptions should be made on the part of the Firm/Company as to this Committee's prior knowledge of their abilities.
- F. Berkeley County reserves the right to request clarification of information submitted and to request additional information of one or more applicants.

XIII. TERMS AND CONDITIONS:

- A. The County Council reserves the right to reject any or all proposals or to award the contract to the next recommended Company if the successful Company fails to execute an agreement within ten (10) calendar days after being notified of the award of this proposal.
- B. Berkeley County reserves the right to request clarification of information submitted and to request additional information of one or more applicants.
- C. Any proposal may be withdrawn up until the date and time set within this RFP for the opening of the proposals. Any proposal not so withdrawn will constitute an irrevocable offer, for a period of ninety (90) calendar days, to sell to Berkeley County the services set forth above, in the manner and at the costs set forth.
- D. The selected Company shall be required to enter into a contract agreement with the County Council. Any agreement or contract resulting from the acceptance of the proposal shall be

made on forms approved by the Berkeley County In-House Legal Director and shall contain, at a minimum, applicable provisions of this request for proposal. The County Council reserves the right to reject any agreement that does not conform to this request for proposal and any Berkeley County requirements for agreements or contracts.

- E. Selected Firm/Company shall not assign any interest in the contract and shall not transfer any interest in the same without prior written consent of the Berkeley County Council.
- F. No reports, information or data given to or prepared by the Firm/Company under this agreement shall be made available to any individual or organization by the Firm/Company without the prior written approval of the Berkeley County Council.
- G. Firms/Companies shall give specific attention to the identification of those portions of their proposals that they deem to be confidential, proprietary information or trade secrets and provide any justification why such materials, upon request, should not be disclosed by the County Council under the West Virginia Freedom of Information Act.
- H. Berkeley County shall not be liable for any costs incurred by the Firm/Company in regard to preparation of its proposal.
- I. Berkeley County reserves the right to request interviews.
- J. The County Council reserves the right to reject any and/or all proposals, to waive technicalities, and to take whatever action is in the best interest of the County.
- K. Berkeley County reserves the right to not hold discussions after award of the contract.
- L. By submitting a proposal, the Firm/Company agrees that it is satisfied, as a result of its own investigations of the conditions set forth in this request, and that it fully understands the obligations set forth therein.
- M. The Firm/Company shall abide by and comply with the true intent of the RFP and its Scope of Work and shall not take advantage of any unintentional error, ambiguity or omission, but shall fully complete every part as contemplated by the true intent and meaning of the scope of services described herein.
- N. The Firm/Company hereby represents and warrants:
 - 1. That it is now, or will be by the time its Proposal is opened, qualified to do business in the State of West Virginia and that it will take such action as, from time to time hereafter, may be necessary to remain so qualified;
 - 2. That it is not in arrears with respect to the payment of any monies due and owing the State, or any department or agency thereof, including, but not limited to, the payment of taxes and employee benefits, and that it shall not fall into arrears during the term of the contract; that it shall comply with all federal, State, and local laws, ordinances, and legally enforceable rules and regulations applicable to its activities and obligations under the contract;
 - 3. That it shall procure, at its expense, all licenses, permits, insurance, and

governmental approvals, if any, necessary to the performance of its obligations under the contract;

4. That the facts and matters set forth hereafter in the contract and made a part hereof are true and correct.
- O. In addition to any other remedy available to Berkeley County, breach of any of the services contracted herein shall, at the election of the County Council, be grounds for termination of the contract. Failure of the County Council to terminate the contract shall not be considered or construed as either a waiver of such breach or as a waiver of any rights or remedies granted or available to Berkeley County.
- P. HOLD HARMLESS/INDEMNIFICATION: If a contract is awarded, the successful Firm/Company will be required to indemnify and hold Berkeley County, its agents and/or employees harmless from and against all liability and expenses, including attorney's fees, howsoever arising or incurred, alleging damage to property or injury to, or death of, any person arising out of or attributable to the Firm's/Company's performance of the contract awarded. Any property or work to be provided by the Firm/Company under the contemplated contract will remain at the Firm's/Company's risk until written acceptance by the County Council; and the Firm/Company will replace, at Firm's/Company's expense, all such property or work damaged or destroyed by any cause whatsoever, prior to its acceptance by the County.
- Q. Termination for Convenience: Berkeley County may terminate this or any contract, in whole or in part, whenever the County Council determines that such termination is in the best interest of the County, without showing cause, upon giving 30 days written notice to the Firm/Company. Berkeley County shall pay all reasonable costs incurred by the Firm/Company up to the date of termination. However, in no event shall the Firm/Company be paid any amount that exceeds the price proposed for the work performed. The Firm/Company will not be reimbursed for any profits which may have been anticipated but which have not been earned up to the date of termination.

Termination for Default: When the Firm/Company has not performed or has unsatisfactorily performed the contract, Berkeley County may terminate the contract for default. Upon termination for default, payment may be withheld at the discretion of the County Council. Failure on the part of a Firm/Company to fulfill the contractual obligations shall be considered just cause for termination of the contract. The Firm/Company will be paid for services satisfactorily rendered prior to termination less any excess costs incurred by Berkeley County in re-procuring and completing the work.
- R. The contractual obligation of Berkeley County under the contemplated contract is contingent upon the availability of appropriated funds from which payment for this contract can be made.
- S. INTERPRETATION: The contract resulting from this proposal shall be construed under the laws of the State of West Virginia.

XIV. INTERPRETATIONS , DISCREPANCIES , OMISSIONS:

Should any Firm/Company find discrepancies in, or omissions from, the documents or be in doubt of their meaning, they should at once request in writing an interpretation from the County Council. All necessary interpretations will be issued to all Firms/Companies in the form of addenda to the specifications, and such addenda shall become part of the contract documents. Failure of any Firm/Company to receive any such addendum or interpretation shall not relieve such Firm/Consultant from any obligation under their proposal as submitted. Berkeley County will assume no responsibility for oral instructions or suggestions. Every interpretation made by Berkeley County will be made in the form of an addendum that, if issued, will be sent by Berkeley County to all interested parties.

LIST OF APPENDICES THAT ARE ATTACHED

Attachment A - Price Proposal

Attachment B - Non-Collusion Certificate

Attachment C – Site Plan for South Raleigh Street and West South Street Transfer Station.

Attachment D – Specifications for the proposed EPTA Transfer Station to be erected on the site.

**ATTACHMENT A
PRICE PROPOSAL**

INSTRUCTIONS

This sheet must be placed on the very top of your price proposal. The County Council will utilize this sheet for purposes of reading the proposal into the public record.

Berkeley County Council
400 West Stephen Street
Suite 201
Martinsburg, WV, 25401

Bid Title: EPTA Site & Building Preparation Work

Bid Due Date & Time: Wednesday, August 14, 2019 NLT 4:00 PM

Bid Opening Date & Time: Thursday, August 15, 2019 @ 10:10 AM

We have received all documents related to the above referenced project. We have examined all documents, attended the mandatory pre-bid conference, and have had the opportunity to examine the site area where work is to be performed. We hereby propose to furnish all labor, materials, equipment and incidentals and to perform all operations necessary and required for the successful completion of the project.

Lump Sum Price for all the **EPTA Site & Building Preparation Work** to be done at the corner of South Raleigh Street and West South Street, Martinsburg, West Virginia, 25401 contained in Request for Proposal including all addendums and attachments:

\$ _____

Contractor Name & Address: _____

By: _____
(Authorized Signature) (Date)

Title: _____

West Virginia Contractor's Number:

**ATTACHMENT B
NON-COLLUSION CERTIFICATE**

I HEREBY CERTIFY I am the _____
(Title)

and the duly authorized representative of the firm of

whose address is _____

AND THAT NEITHER I nor, to the best of my knowledge, information and belief, the above firm nor any of its other representatives I here represent have:

- (a) Agreed, conspired, connived or colluded to produce a deceptive show of competition in the compilation of the bid or offer being submitted herewith;
- (b) Not in any manner, directly or indirectly, entered into any agreement, participated in any collusion to fix the bid price or price proposal of the bidder or offeror herein or any competitor, or competitive bidding in connection with the Contract for which the within bid or offer is submitted; and that no member of the County Council of Berkeley County, West Virginia, administrative or supervisory personnel or other employees of Berkeley County have any interest in the bidding company except as follows: (complete if applicable)

I solemnly affirm under the penalties of perjury that the contents of the foregoing paper are true to the best of my knowledge, information, and belief.

Date

Signature

Printed or Typed Name

ATTACHMENT “C”

ATTACHMENT “D”

3' x 12' Hip Peak Roof she

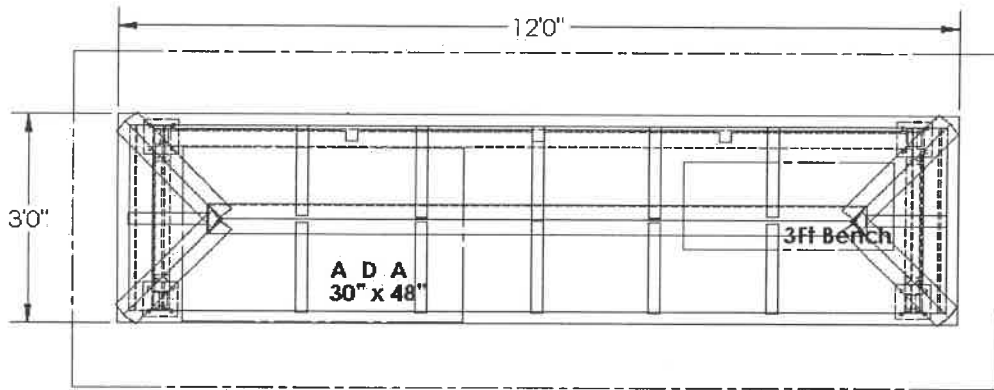

3
3 SHELTER TOP VIEW
Scale: 1/2"=1'

Typical concrete pad depth 6"
may vary depending on final engineering
(1ft all around the footprint)

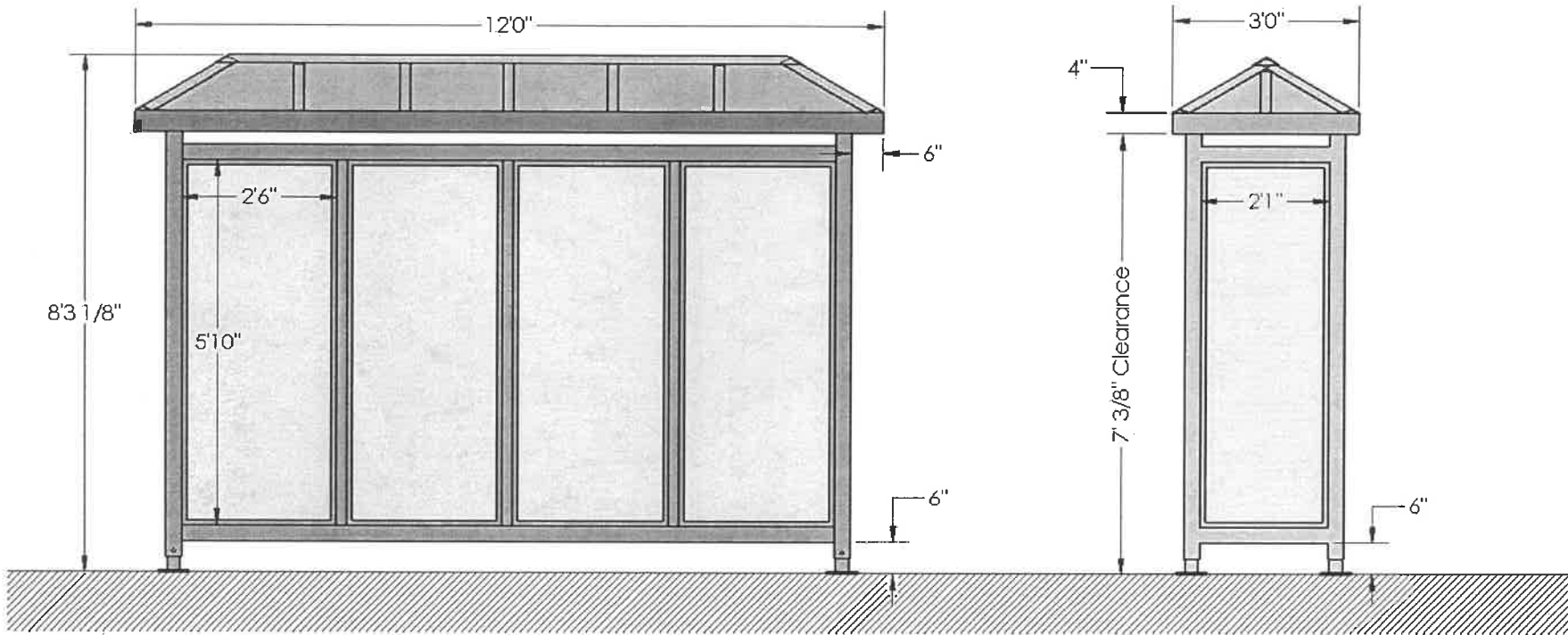

1
3 SHELTER FRONT VIEW
Scale: 1/2"=1'

2
3 SIDE FRONT VIEW
Scale: 1/2"=1'

ME: West Virginia Shelters / Peak Roof		CLIENT APPROVAL		DATE
REVISION	DATE	DESCRIPTION		
NA	Design Date: 10-30-17	Scale: as noted		Drawn by: J.C.

THIS IS AN ORIGINAL UNPUBLISHED DRAWING BY DECAML. IT IS SUBMITTED FOR YOUR PER IN CONNECTION WITH A PROJECT BEING PL BY YOU BY AC SIGNS. IT IS NOT TO BE SHOWN OUTSIDE YOUR ORGANIZATION, NOR IS IT TO BE REPRODUCED, COPIED, OR EXHIBIT IN AN

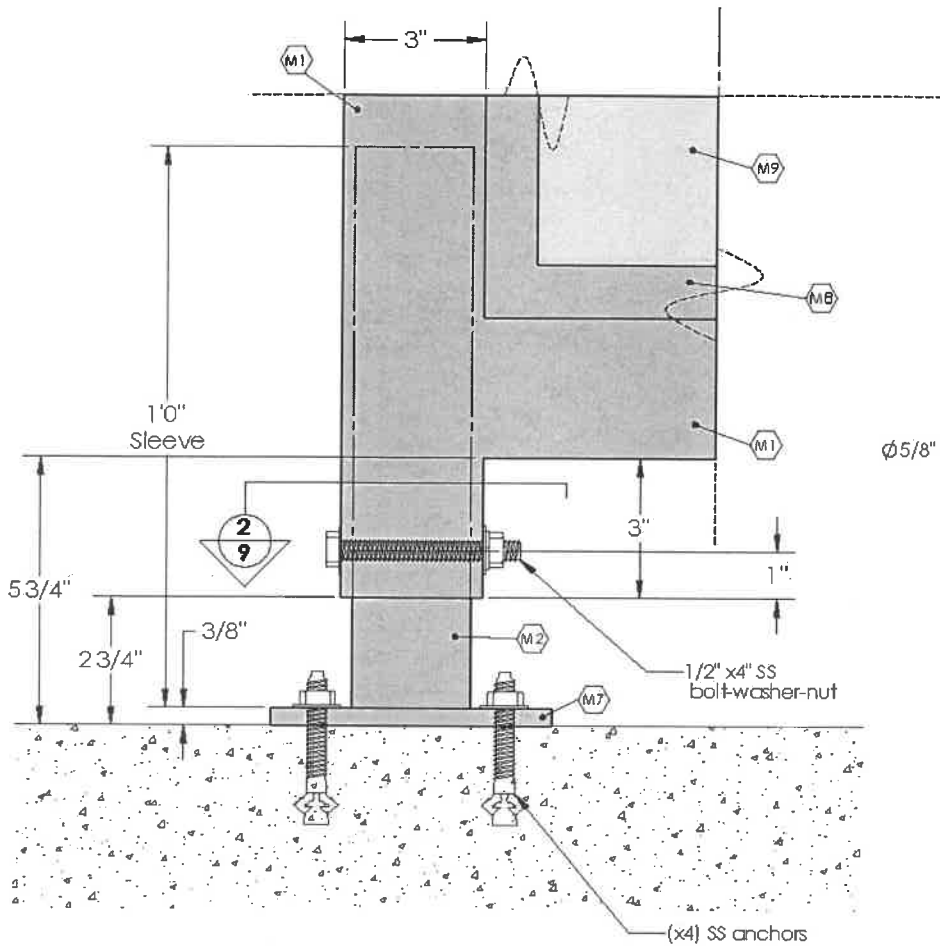

1
9 **SLEEVE-LEG DETAIL**
Scale: 4"=1'

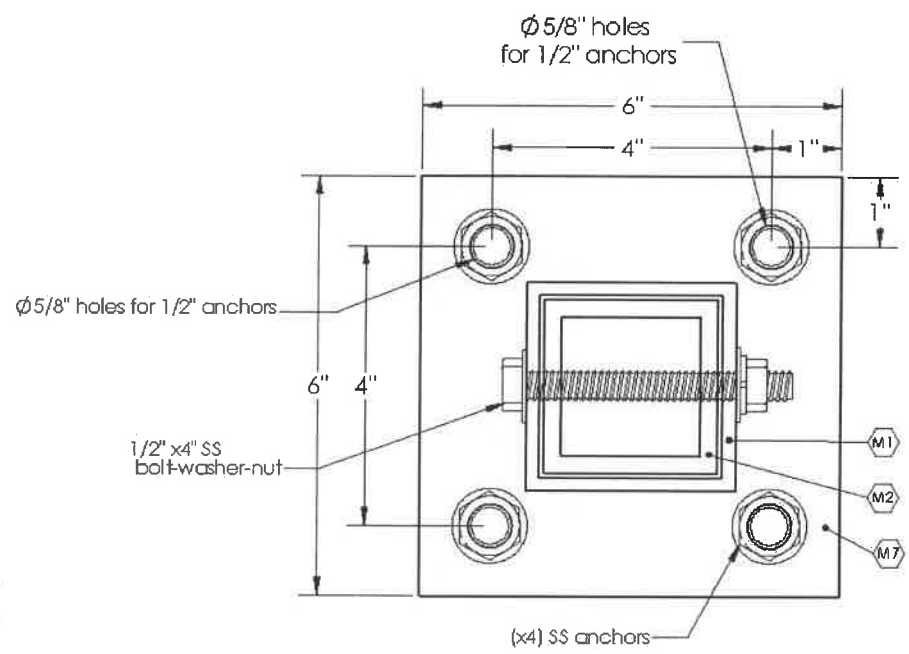

2
9 **BASE PLATE DETAIL**
Half Scale

MATERIAL FINISH	
(F1)	Powder Coating
MATERIALS -	
(M1)	3"x3"x3/16" Alum
(M2)	2.5"x2.5"x1/4" A
(M3)	2"x5"x1/4" Alum
(M4)	1"x2"x1/8" Alum
(M5)	2"x4" Alum recti
(M6)	2"x2"x1/8" Alum
(M7)	3/8" Alum plate
(M8)	Alum "F" Channi
(M9)	1/4" Clear glass
(M10)	0.063" Alum she
(M11)	1/8"x2" Alum flai
(M12)	1/8" SCH 40 Alu
(M13)	125" Alum perfo

ME: West Virginia Shelters / Peak Roof
 Design Date: 10-30-17
 NA Scale, as noted Drawn by: LC

CLIENT APPROVAL			DATE
REVISION	DATE	DESCRIPTION	

THIS IS AN ORIGINAL UNPUBLISHED DRAWING BY DECA.MIL. IT IS SUBMITTED FOR YOUR PERS IN CONNECTION WITH A PROJECT BEING PL BY YOU BY AC SIGNS. IT IS NOT TO BE SHOWN TO OUTSIDE YOUR ORGANIZATION, NOR IS IT TO BE REPRODUCED, COPIED, OR EXHIBIT IN AN

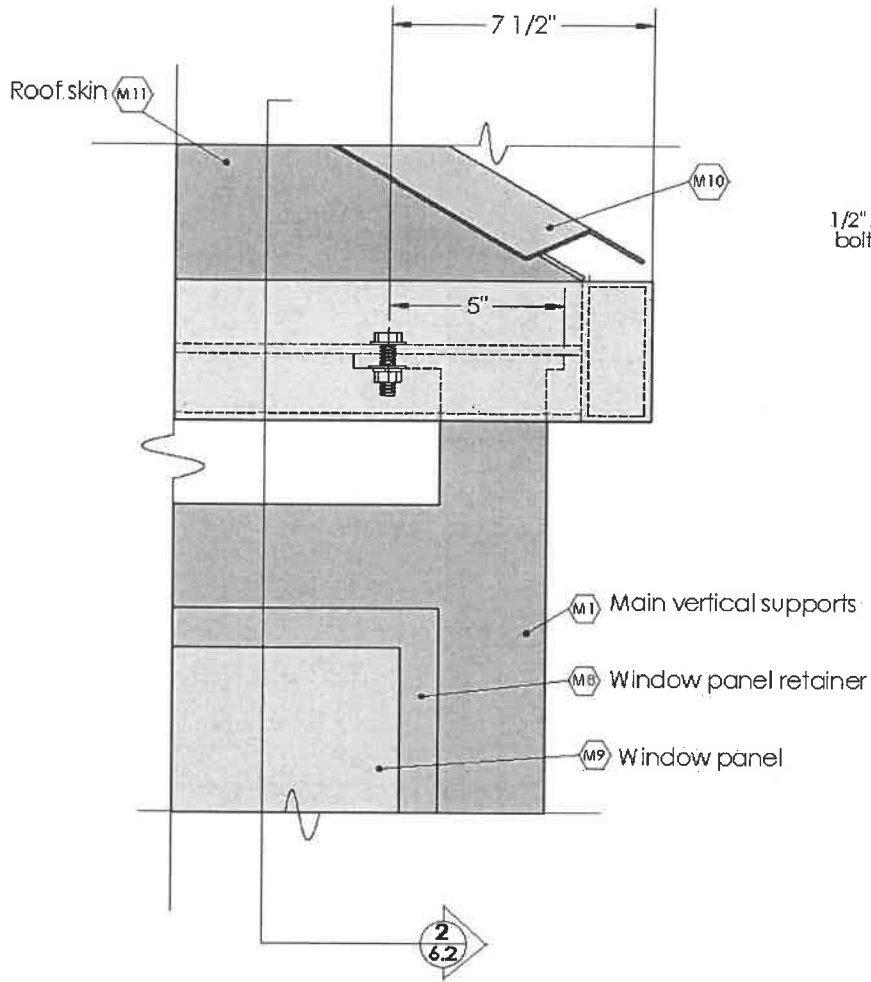

1
10 **ROOF ASSEMBLY SIDE DETAIL**
Scale: 3"=1'

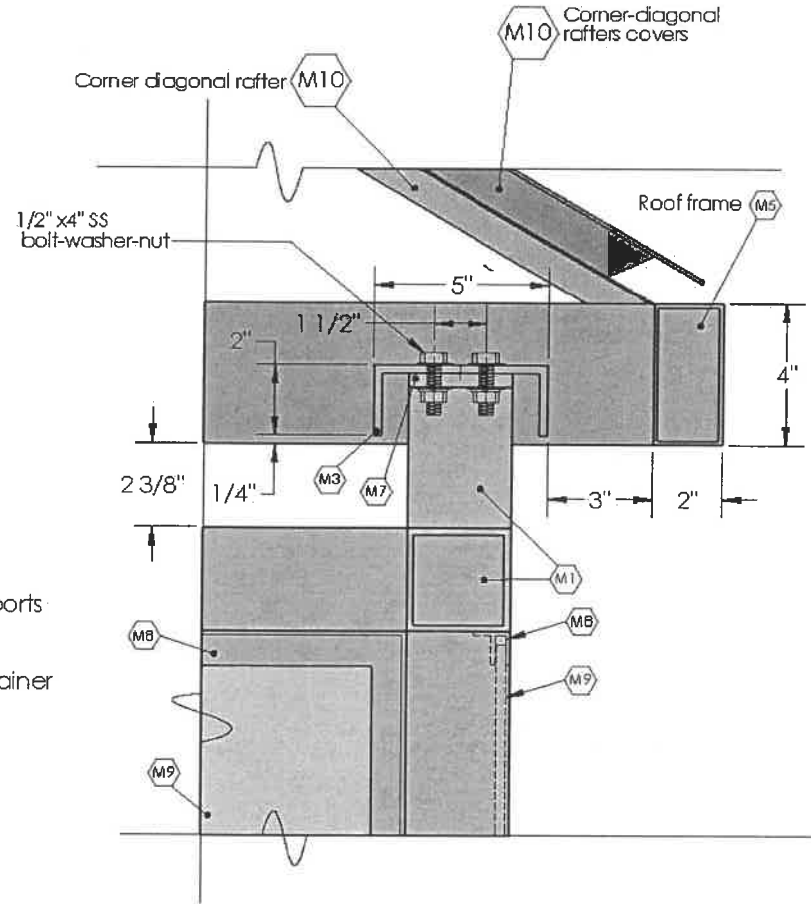

2
10 **ROOF ASSEMBLY CUT SECTION**
Scale: 3"=1'

MATERIAL FINISH:

(F1) Powder Coating

MATERIALS -

- (M1) 3"x3"x3/16" Alur
- (M2) 2.5"x2.5"x1/4" A
- (M3) 2"x5"x1/4" Alum
- (M4) 1"x2"x1/8" Alur
- (M5) 2"x4" Alum rect
- (M6) 2"x2"x1/8" Alum
- (M7) 3/8" Alum plate
- (M8) Alum "F" Channi
- (M9) 1/4" Clear glass
- (M10) 0.063" Alum she
- (M11) 1/8"x2" Alum flat
- (M12) 1/8" SCH 40 Alu
- (M13) .125" Alum perfo

ME: West Virginia Shelters / Peak Roof

CLIENT APPROVAL _____ DATE _____

REVISION	DATE	DESCRIPTION

Design Date: 10-30-17

Scale: as noted Drawn by: LC

THIS IS AN ORIGINAL UNPUBLISHED DRAWING BY DECAML. IT IS SUBMITTED FOR YOUR PERUSE IN CONNECTION WITH A PROJECT BEING PLANNED BY YOU BY AC SIGNS. IT IS NOT TO BE SHOWN TO ANYONE OUTSIDE YOUR ORGANIZATION, NOR IS IT TO BE REPRODUCED, COPIED, OR EXHIBITED IN ANY MANNER WITHOUT THE WRITTEN PERMISSION OF DECAML.

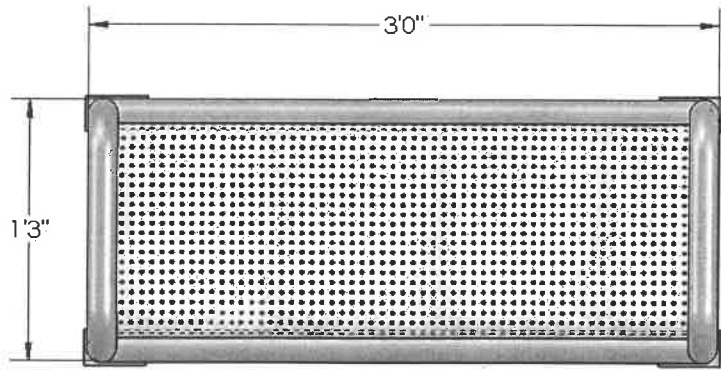

1
12 TOP VIEW
Scale: 1 1/2"=1'

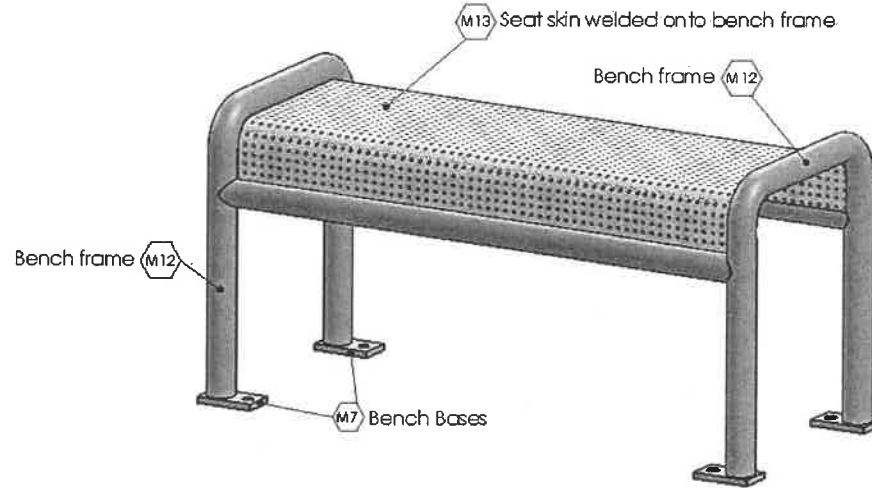

4
12 ISOMETRIC VIEW
Scale: 1 1/2"=1'

MATERIAL FINISH	
(F1)	Powder Coating
MATERIALS -	
(M1)	3"x3"x3/16" Alum
(M2)	2.5"x2.5"x1/4" A
(M3)	2"x5"x1/4" Alum
(M4)	1"x2"x1/8" Alum
(M5)	2"x4" Alum rect 1
(M6)	2"x2"x1/8" Alum
(M7)	3/8" Alum plate
(M8)	Alum "F" Channe
(M9)	1/4" Clear glass
(M10)	0.063" Alum she
(M11)	1/8"x2" Alum flat
(M12)	1/8" SCH 40 Alu
(M13)	125" Alum perfo

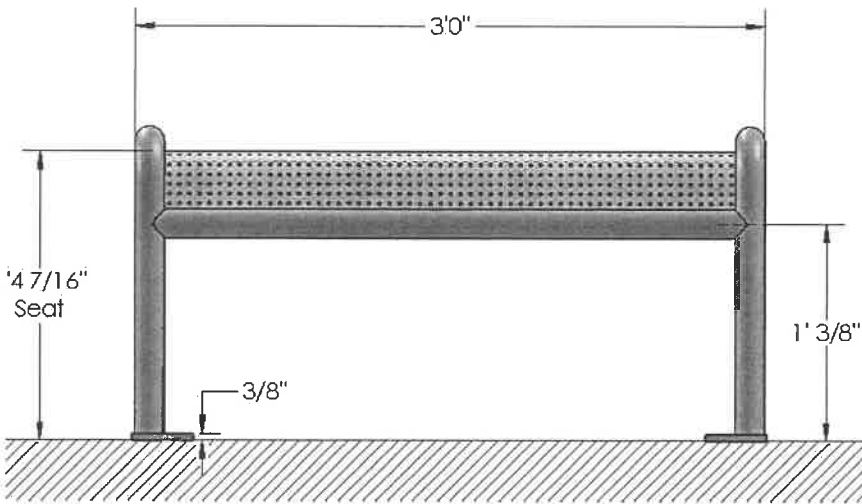

2
12 FRONT VIEW
Scale: 1 1/2"=1'

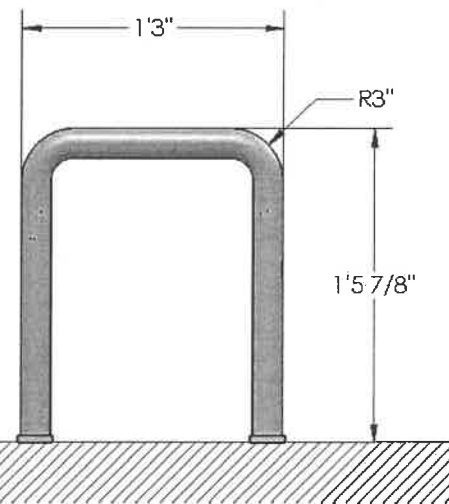

3
12 SIDE VIEW
Scale: 1 1/2"=1'

ME: West Virginia Shelters / Peak Roof		CLIENT APPROVAL		DATE
REVISION	DATE	DESCRIPTION		
NA	Scale, as noted	Design Date: 10-30-17	Drawn by: IC	

THIS IS AN ORIGINAL UNPUBLISHED DRAWING BY DECA.MIL. IT IS SUBMITTED FOR YOUR PERUSE IN CONNECTION WITH A PROJECT BEING PLANNED BY AC SIGNS. IT IS NOT TO BE SHOWN TO ANYONE OUTSIDE YOUR ORGANIZATION, NOR IS IT TO BE REPRODUCED, COPIED, OR EXHIBITED IN ANY MANNER WITHOUT THE WRITTEN CONSENT OF DECA.MIL.